



# Exatouch Installation Guide

## Hardware Model: FEC PP 9735

<b>Introduction</b> .....	1
<b>Preinstallation</b> .....	1
Preinstallation Checklist .....	1
<b>Exatouch Site Readiness</b> .....	2
What's Included.....	2
Additional Hardware .....	2
ISP Modem/Router Connectivity.....	3
Network Speed .....	3
Network Wiring Requirements .....	3
Electric Requirements.....	4
Construction .....	4
<b>Installation</b> .....	4
Best Practices - Installation Schedule and Locations.....	4
Connecting ISP Modem/Router .....	5
Connecting the All-in-One Terminal .....	5
Connecting Printers.....	6
Installing the Epson Thermal Receipt Printer.....	6
Installing the Remote Printer .....	7
Connecting Pin Pads to the Exatouch System .....	8
Connecting Dejavoo Z6 and QD5 Pin Pads .....	8
Connecting PAX S300 and PAX A35 Pin Pads .....	8
<b>Additional Peripherals</b> .....	9
Connecting the Keyboard/Mouse .....	9
Connecting the Barcode Scanner.....	9
Connecting Scales.....	10
<b>Exatouch Wiring Diagrams</b> .....	11

# Introduction

These procedures provide instructions to help users successfully install and operate the hardware components of the Exatouch Point of Sale (POS) system.

This document is intended to be a Quick Reference Guide and does not incorporate all capabilities and features available in the Exatouch POS system.

## Preinstallation

### Preinstallation Checklist

This checklist provides a list of steps that must be performed or verified before installing your Exatouch POS system. Review this checklist before installation to avoid delays.

Completed	Service/Items to Verify	Reference Page
<input type="checkbox"/>	Hardware components	Page 2
<input type="checkbox"/>	Modem/router connectivity	Page 3
<input type="checkbox"/>	Network speed	Page 3
<input type="checkbox"/>	Network wiring requirements	Page 3
<input type="checkbox"/>	Electric requirements	Page 4
<input type="checkbox"/>	Construction	Page 4
<input type="checkbox"/>	General best practices	Page 4

# Exatouch Site Readiness

Verify all hardware components are present before beginning an Exatouch installation. Exact models of some equipment and configurations may vary. The following equipment comes with your Exatouch POS system; additional hardware is also listed.

## What's Included



1. Customer Facing Display
2. Router
3. Barcode Scanner
4. All-in-One Terminal

5. Cash Drawer
6. PAX or Dejavoo Pin Pad
7. Printer

## Additional Hardware

- Keyboard/Mouse
- Ethernet cables (3)
- USB-A to USB-B cable
- USB power adapter
- USB-A to Micro-USB cable
- Employee cards (3 or 15)
- Two (2) rolls of starter receipt paper

## ISP Modem/Router Connectivity

Connect the modem and verify that it is activated.

1. Verify internet connection.
2. Plug modem into a power outlet.
3. Call your Internet Service Provider (ISP) to confirm service is active.
4. Connect a laptop or PC to the modem to verify service.
5. Verify DHCP is enabled on the network.

## Network Speed

Merchants should perform a network speed test to ensure that your current internet speed supports operation of the Exatouch POS. Run a speed test by visiting <http://www.speedtest.net>. Current requirements include the following:

- Download speed – Minimum of 5.0 Mbps
- Upload speed – Minimum of 30.5 Mbps
- Business-class internet connections are recommended.

## Network Wiring Requirements

The following hardware requires an ethernet cable:

- Exatouch POS system
- Kitchen/remote printer
- Kitchen display system
- Caller ID
- Credit card terminal

**NOTE:** Each Exatouch lane (station) requires two ethernet cables. Cables are provided as part of your equipment bundle, but you may need to purchase longer cables to accommodate your station setup.

## Electric Requirements

Ensure the following electric requirements are followed:

- Make sure adequate power outlets exist.
- Use a surge protector.
- Modern power systems are recommended. Avoid knob and tube wiring.

## Construction

Make sure any construction projects are completed before installation, including the following:

- Sheet rock
- Painting
- Counters
- Flooring

## Installation

### Best Practices - Installation Schedule and Locations

- Schedule installation when you're closed or not busy.
- Allow at least one hour for the initial Exatouch installation.
- Allow 30-45 minutes for additional stations.
- Reserve at least 24" x 24" of space per Exatouch station.
- Avoid installing an Exatouch station in the following locations:
  - Near fryers
  - Hot or damp areas
  - On cardboard boxes
  - Mobile carts
  - Collapsible tables
  - The floor

## Connecting ISP Modem/Router

Connect the provided router to your existing ISP gateway. This router is required for setup.

1. Plug one end of an ethernet cable into the WAN port on the back of the router.

**NOTE:** The WAN port connects the router to the internet.

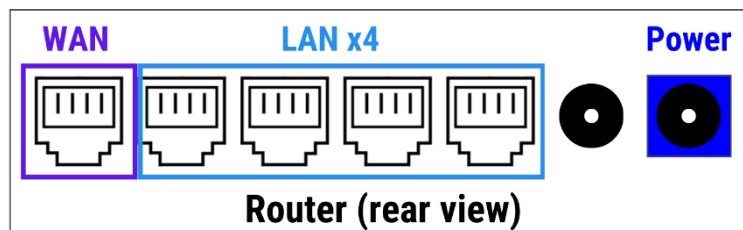

2. Connect the other end of the cable to a LAN port on your ISP gateway.  
**NOTE:** LAN ports share internet connections with other Exatouch devices.
3. Plug the router power cable into the power outlet. A surge protector is recommended.

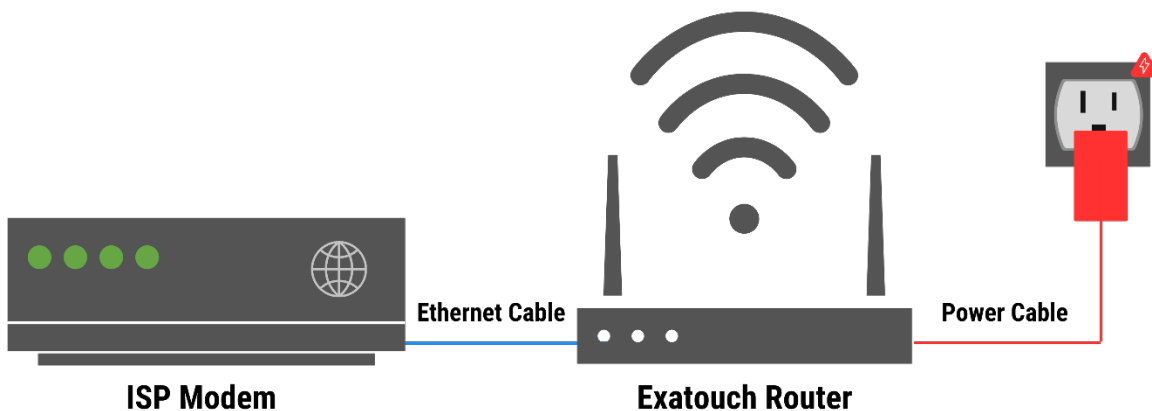

## Connecting the All-in-One Terminal

1. Connect one end of an ethernet cable to the LAN port nearest to the power cable port underneath the All-in-One Terminal.
2. Plug the other end of an ethernet cable into an available LAN port behind the router.
3. Plug the All-in-One Terminal power cable into a power outlet.

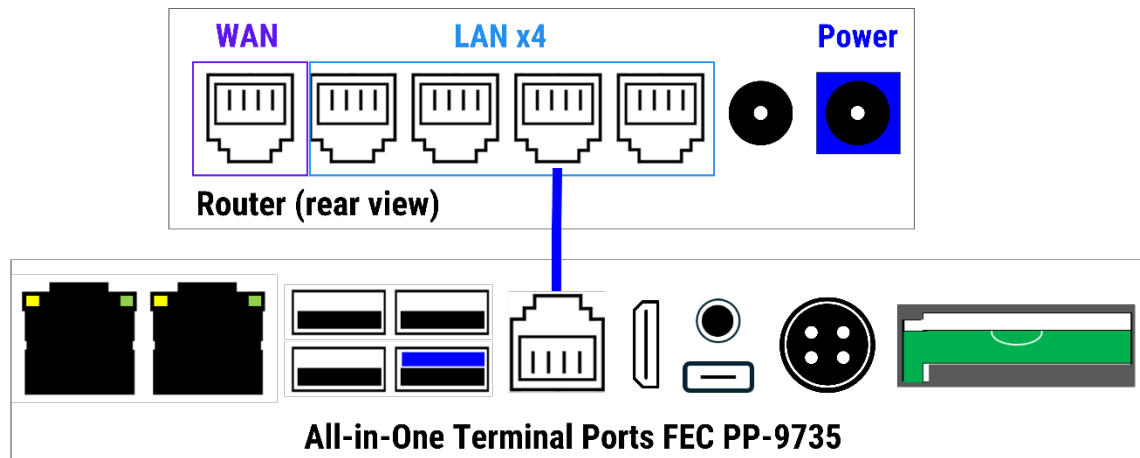

4. Press the power button at the bottom right of the All-in-One Terminal, on the back.
5. If using a Customer Facing Display (CFD) with the All-in-One Terminal:
  - a. For the Rear-Mount CFD, connect the CFD's integrated USB-C tab into the All-in-One Terminal's USB-C port, underneath the cover plate at the top of the terminal.
  - b. For the Independent-Mount CFD, connect the Smart DD cord from the CFD to the corresponding port on the All-in-One Terminal. The CFD may then be placed anywhere within the reach of the cord.

## Connecting Printers

### Installing the Epson Thermal Receipt Printer

This procedure describes printer port connections. Refer to the "Epson Thermal Receipt Printer Setup Guide" that came with your Exatouch bundle for detailed instructions.

1. Remove bottom panel of printer to display interior ports. Note that there are three models of Epson Thermal Printers available through EPI: the TM-M30, the TM-M30ii, and the TM-M30iii.

### EPSON THERMAL PRINTER TM-M30

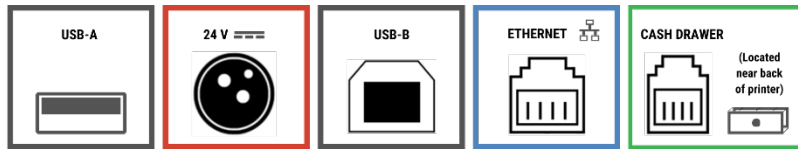

### EPSON THERMAL PRINTER TM-M30ii



### EPSON THERMAL PRINTER TM-M30iii

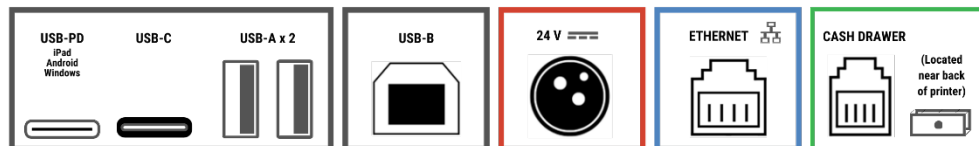

2. Connect the printer to the All-in-One Terminal.
  - a. Plug the USB-B end of a USB-A to USB-B cable into the USB-B port of the printer.
  - b. Connect the other end of the cable to the All-in-One Terminal.
3. Connect the printer to the cash drawer.
  - a. Plug the RJ11 end of the ethernet-to-phone cord into the phone jack port of the printer.
 

**NOTE:** The RJ11 port is located underneath the printer, near the back panel.
  - b. Connect the ethernet end of the cord to the cash drawer.
4. Plug the power adapter into the 24V power supply connector of the printer.
5. Activate the printer by pressing the power button on top of the device.
6. On the All-in-One Terminal, configure printer options:
  - a. Go to **Home > Settings > Print Settings** and tap the **Receipt Options** tab to set up the receipt printer.

### Installing the Remote Printer

1. Access ports on bottom panel of the printer.
2. Connect the printer to the router using an RJ45/Cat cable.
3. Plug the printer into a power source.
4. Activate the printer by pressing the power button.



5. On the All-in-One Terminal, configure remote print options:
  - a. Go to **Home > Settings > Print Settings** and tap the **Remote Options** tab to set up the remote printer.

## Connecting Pin Pads to the Exatouch System

### Connecting Dejavoo Z6 and QD5 Pin Pads

1. Plug the Micro-USB end of a USB-A to Micro-USB cord into the port box on the pin pad cable.
2. Plug the USB-A end of the cord into the provided USB/outlet adapter.
3. Insert one end of an ethernet cable into the cable box of the pin pad cable.
4. Connect the other end of the ethernet cable to an available LAN port on the back of the router.

**NOTE:** The Dejavoo Z6 will use the red LAN port. The other two ports are unused.

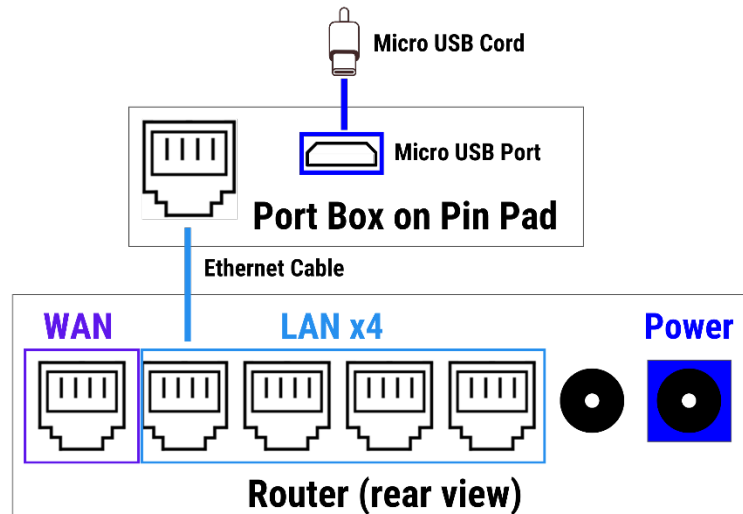

### Connecting PAX S300 and PAX A35 Pin Pads

1. Mount the PAX pin pad in the desired location.
2. Connect one end of the ethernet cable into an available LAN port on the router.
3. Connect the other end of the ethernet cable into the red LAN connector on the pin pad.
4. Plug the pin pad into a power source.

**NOTE:** Only the red LAN connector requires connection. The RS232A and RS232B cable ends are not used when interfacing PAX pin pads with Exatouch. VGA connectors are also not required.

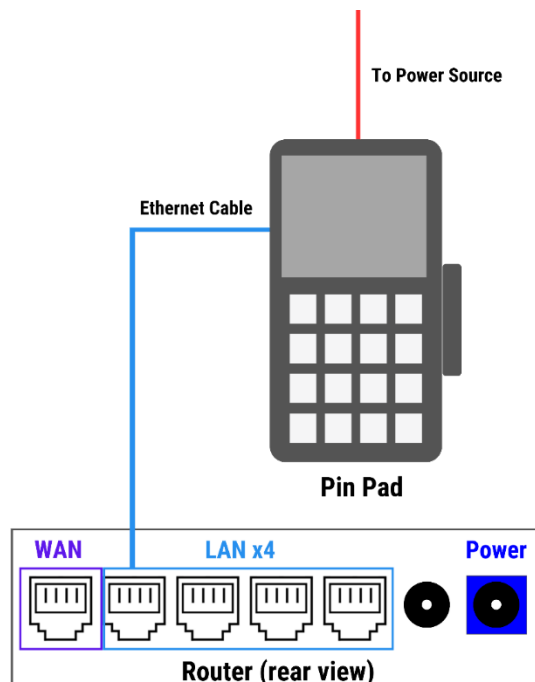

## Additional Peripherals

### Connecting the Keyboard/Mouse

1. Locate Keyboard/Mouse wireless USB dongle (usually located within the mouse or keyboard battery compartment). **NOTE:** Only one dongle is needed for both the keyboard and mouse.
2. Insert the dongle into any available USB port on the All-in-One Terminal.

### Connecting the Barcode Scanner

**NOTE:** Retain the manual that came with your barcode scanner for future use.

1. Assemble the scanner stand.
2. Fasten the scanner to the scanner stand.
3. Plug the scanner cable into an available USB port underneath the All-in-One Terminal.

## Connecting Scales

Perform the following to connect scales to Exatouch:

1. When setting up a scale, ensure that it is on a flat/level surface and the level bubble is centered.
2. Connect the scale to Exatouch using a serial cable (Tor Rey and DataLogic) or USB-A (CAS).
3. Plug the scale into a power supply.
4. Press the On button to activate the scale.
5. If connecting a DataLogic Magellan 9400i In Counter Scanner/Scale, plug the remote display into the scale.
6. Allow a 15-minute warmup period before operating the scale.

**NOTE:** Scales may need drivers or additional configuration after the cables have been connected and equipment powered on. Please contact the Exatouch Tech Support Team to finalize the setup process.

# Exatouch Wiring Diagrams

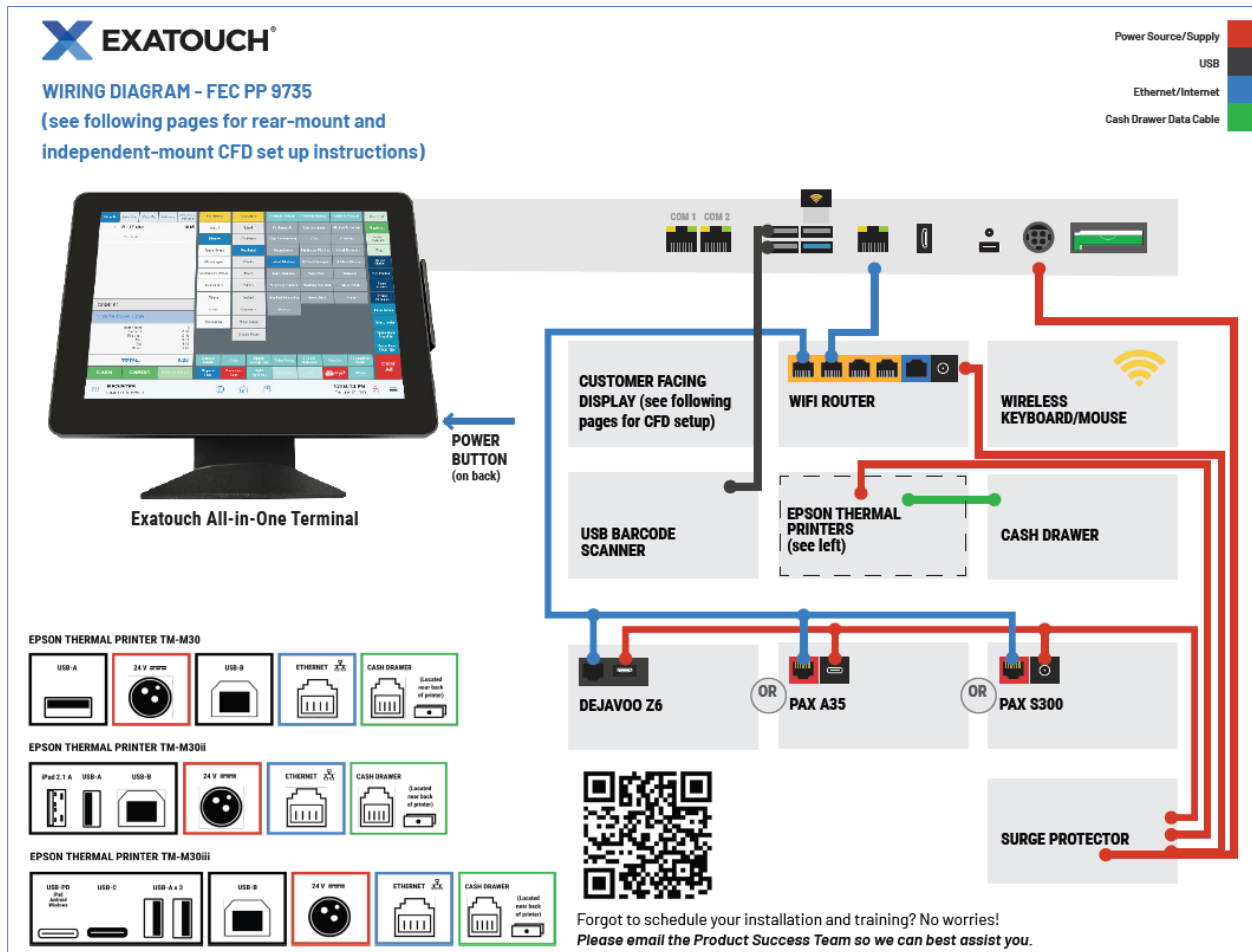



**WIRING DIAGRAM - FEC PP 9735**  
Rear-mount CFD set up



Please contact the Product Success Team for assistance setting up your Exatouch All-in-One Terminal with Customer Facing Display.



**Exatouch All-in-One Terminal with rear-mount Customer Facing Display**

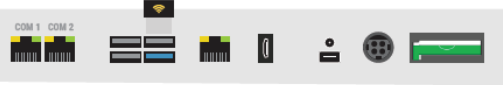

**Rear-mount CFDs have the wiring incorporated into the display. Follow the instructions below to seat the CFD into the All-in-One Terminal. No external wiring is needed.**

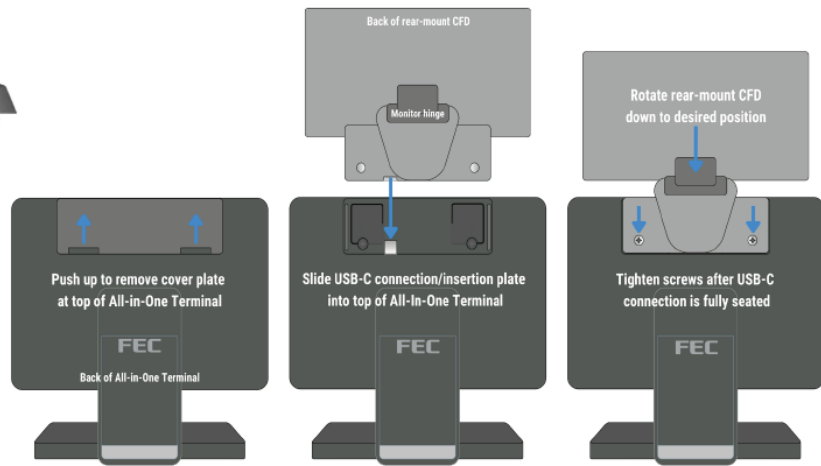



**WIRING DIAGRAM - FEC PP 9735**  
**Independent-mount CFD set up**



*Please contact the Product Success Team for assistance setting up your Exatouch All-in-One Terminal with Customer Facing Display.*



**Exatouch All-in-One Terminal**



**The independent-mount CFD connects to the Smart DD port on the All-in-One Terminal. This CFD may be placed anywhere.**



**Independent-mount Customer Facing Display**

Scan the QR code to see **Exatouch Quick Reference and User Guides**.  
For assistance, contact our 24/7 Technical Support Team  
at (800) 966-5520 – Option 3 or [support@electronicpayments.com](mailto:support@electronicpayments.com).

